

Seat No.	
-------------	--

[5559]-118

S.E. (Mechanical/Automobile/Mech. S/W)

(I Sem.) EXAMINATION, 2019

STRENGTH OF MATERIALS

(2015 PATTERN)

Time : Two Hours

Maximum Marks : 50

N.B. :- (i) Solve Q. 1 or 2, Q. 3 or 4, Q. 5 or 6, Q. 7 or 8.

(ii) Neat diagrams must be drawn wherever necessary.

(iii) Figures to right indicate full marks.

(iv) Use of Electronic pocket calculator is allowed

(v) Assume suitable data if necessary

1. (a) A homogeneous bar with a cross sectional area of 500 mm^2 is attached to rigid supports. It carries the axial loads $P_1 = 25 \text{ kN}$ and $P_2 = 50 \text{ kN}$, applied as shown in Fig.1. Determine the stress in segment BC and CD [6M]

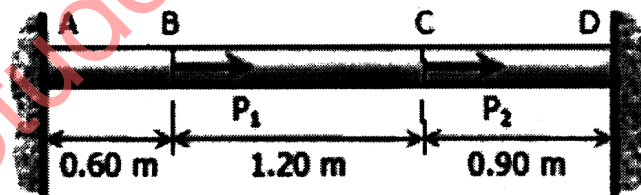

Fig. 1

- (b) A beam AB 8 meters long has supports at its ends A and B. It carries a point load of 10 kN at 2.5 meters from A and a point load of 7 kN at 7 meters from A and a uniformly distributed load of 2 kN per meter between the point loads. Draw SF and BM diagrams for the beam. [6M]

P.T.O.

OR

2. (a) The bulk modulus of material is 50GPa. A 12 mm diameter rod of material was subjected to axial load of 14 KN and the change in diameter was observed 0.0036 mm. Calculate Poisson's ratio and modulus of elasticity for material. [6M]
- (b) Fig 2 shows SFD. Draw loading diagram and BMD. Also find point of contraflexure if any [6M]

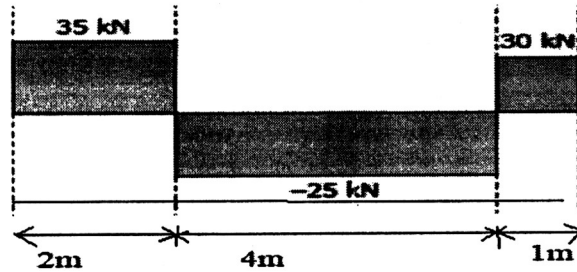

Fig2

3. (a) Find deflection at point B and C of cantilever beam shown in fig.3. Cross section of beam is 150 X 250 mm and take $E = 200$ GPa. [6M]

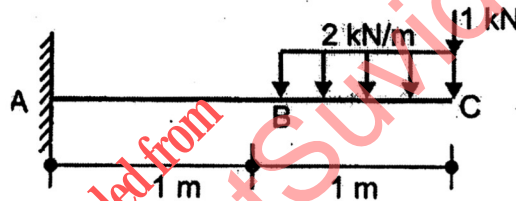

Fig3

- (b) Cross section of beam is shown in fig.4. Calculate central point load that SSB of span of 4m can carry if permissible stresses in bending are 120 MPa in compression and 40 Mpa in tension . Take $I_{NA} = 425.17 \times 10^6 \text{ mm}^4$ [6M]

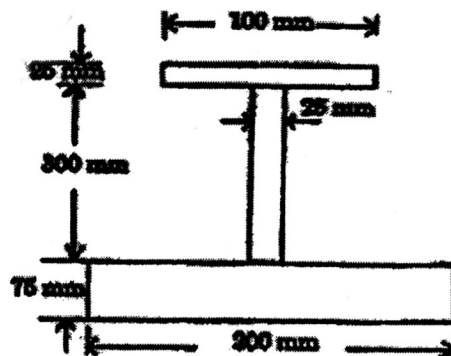

Fig. 4

OR

4. (a) A steel section, as shown, in Fig.5 is subjected to a shear force of 15 KN. Determine the shear stress at key points and sketch the shear stress distribution diagram [6M]

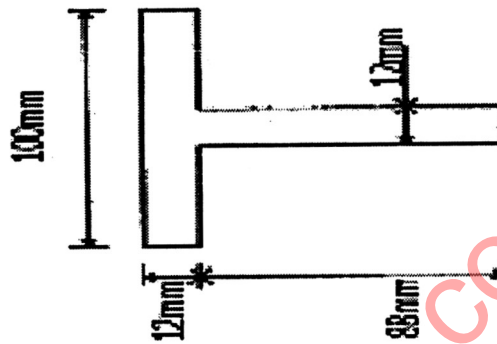

Fig. 5

- (b) A load of 100 N falls through height of 2cm on a collar rigidly attached to lower end of vertical bar 1.5m long and cross section of bar is rectangular 15 X 10 mm. The upper end of vertical bar is fixed. Determine Maximum instantaneous stress developed in vertical bar and strain energy stored in vertical bar. Take $E = 200 \text{ GPa}$ [6M]
5. (a) A solid shaft of 180 mm diameter has the same cross-sectional area as that of hollow shaft of the same materials of inside diameter 130 mm. Find out the ratio of power transmitted by the two shafts for same angular velocity. Consider shear stress developed in both shafts is same. [6M]
- (b) Compare the crippling load given by Euler's and Rankine's formula for a tubular steel strut 2.3 m long having external diameter 38 mm and internal diameter 33 mm. Strut is fixed at one end and hinged at other end. Yield stress for steel 335 MPa, $E = 205 \text{ GPa}$, $a = 1/7500$ [7M]

OR

6. (a) For a hollow steel shaft shown in fig6. applied torque is 2400 N-m. Length of shaft is 500mm, outer diameter D_2 is 50mm and inner diameter is D_1 is 40 mm. Determine maximum and minimum shear stress in the shaft and angle of twist at free end. Take modulus of rigidity 77 GPa [6M]

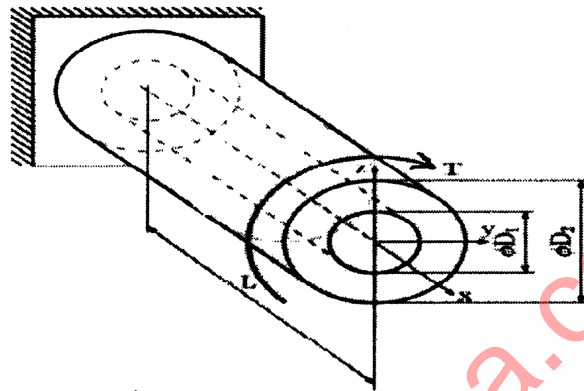

Fig 6

- (b) Determine the buckling load for a strut of tee section, the flange width being 100 mm, overall depth 80 mm and both flange and web 10 mm thick. The strut is 3 m long and is hinged at both ends. Take $E = 200 \text{ GN / m}^2$ thick by using Euler formulae [7M]
7. (a) A plane element is subjected to stresses as shown in fig.7. Determine principal stresses, maximum shear stress and normal stress on plane inclined at 45° as shown in fig. using Mohr's circle [7M]

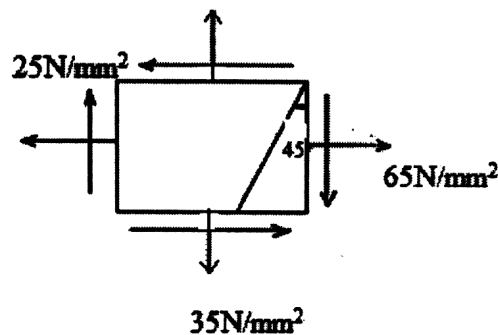

Fig 7

- (b) An axial pull of 20 kN along with a shear force of 15 kN is applied to a circular bar. The elastic limit of the bar material is 230 MPa, factor of safety is 2 and the Poisson's ratio, $\mu = 0.3$. Determine the diameter of circular bar based on
- Maximum shear stress theory
 - Maximum principal stress theory
- [6M]

OR

8. (a) A point in strained material is subjected to stresses as shown in fig.8. Find principal stresses, maximum shear stress and positions of principal plane
- [7M]

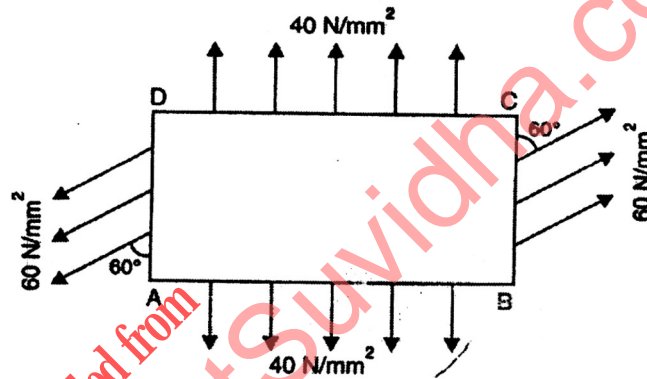

Fig8

- (b) At a section of mild steel shaft of diameter 180 mm, the maximum torque is 67.5 KN-m and maximum bending moment is 40KN-m. Determine whether the failure of material will occur or not according to maximum shear stress theory. If not, then find factor of safety. Take $\sigma_y = 220N/mm^2$
- [6M]